

INFRATECH™

a SEACHROME company

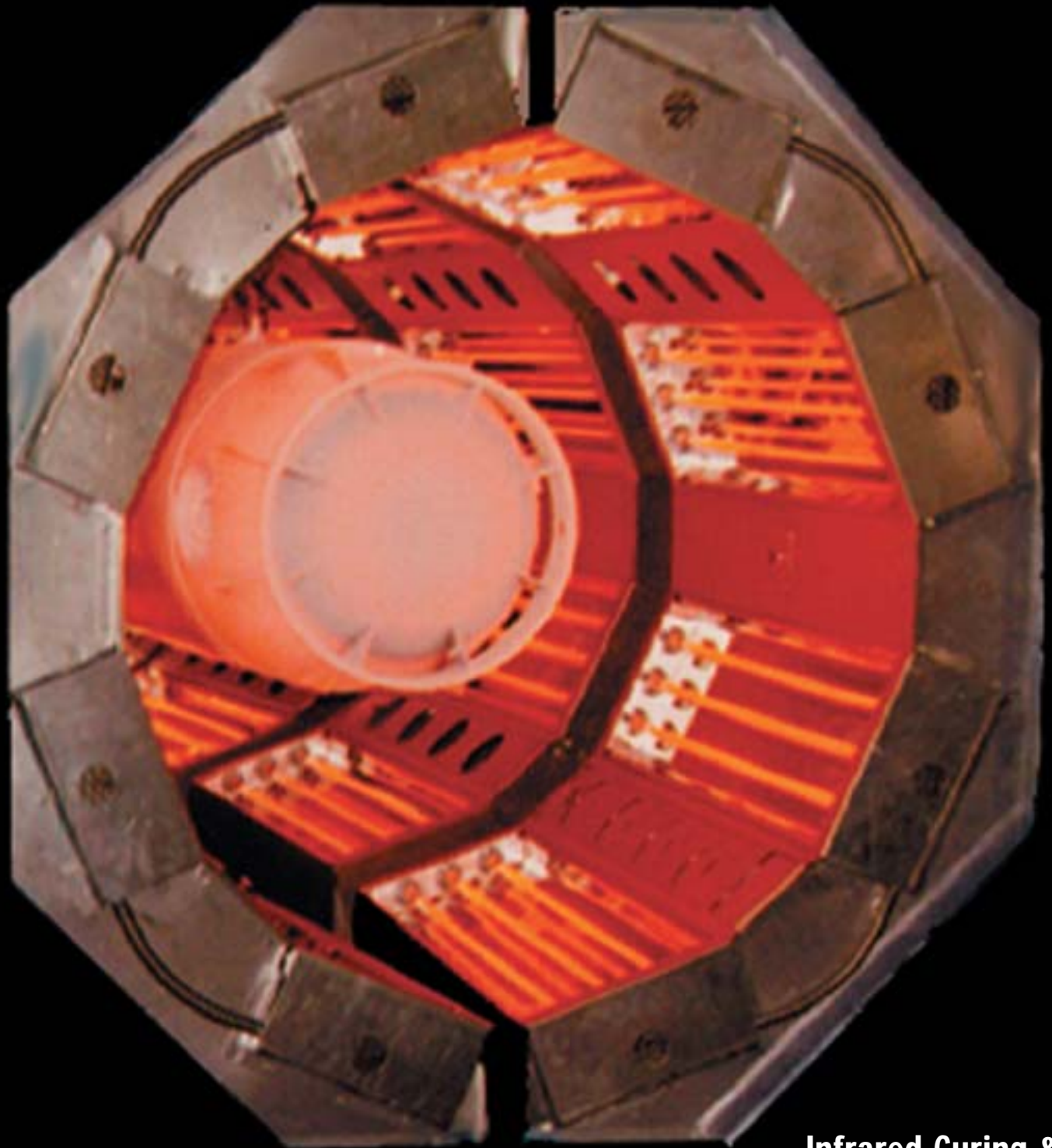

**Infrared Curing &
Drying Technology**

Portable Medium Wave Systems

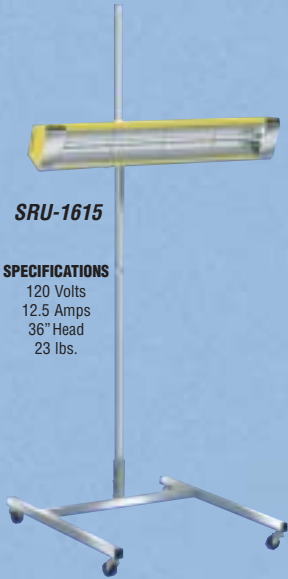

SRU-1615

SPECIFICATIONS
 120 Volts
 12.5 Amps
 36" Head
 23 lbs.

MODEL SRU-1615

Part No. 14-1000

- Number one selling portable infrared unit
- 1500 Watts of curing power over a 2' X 3' coverage area - ideal for small area repairs
- New heavy-duty stand adjusts to over 6' high
- Now with conveniently located On/Off switch
- Parabolic reflector for uniform heat distribution
- Energy efficient, only pennies per hour to operate
- Underwriters Laboratories (U.L.) Listed

MODEL SRU-3215

Part No. 14-1005

- Same quality features as SRU-1615
- Includes "two" 1500 Watt heads for double the curing power over a 3' X 4' coverage area (3000 Watts total)

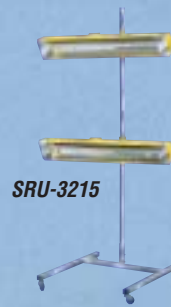

SRU-3215

SPECIFICATIONS
 120 Volts
 26 Amps
 36" Heads
 35 lbs.



SRU-1615-HT

SPECIFICATIONS
 120 Volts
 18 Amps
 36" Head
 26 lbs.

MODEL SRU-1615-HT

Part No. 16-1000

- HIGH INTENSITY Medium Wave for increased power (2000 Watts) and improved cure times over a 3' X 4' coverage area
- Vertical or horizontal operation for curing hard to reach areas and increased flexibility for small repairs
- 60 minute timer saves energy and turns off unit when curing is complete
- New heavy-duty stand adjusts to over 6' high
- Underwriters Laboratories (U.L.) Listed

MODEL S-2002

Part No. 16-1020

- HIGH INTENSITY Medium Wave infrared technology with 4000 Watts of curing power
- Solid state, programmable control with electronic timer for reliability, accuracy and ease of use
- Large area of coverage (4' X 4')
- Parabolic reflectors for uniform heat distribution
- Multi-position stand with locking casters has a narrow foot print for mobility
- Adjustable shock arm extends to over 7' high
- Equipped with 25' power cord
- Underwriters Laboratories (U.L.) Listed



S-2002

SPECIFICATIONS
 240 Volts
 18 Amps
 39" Heads
 160 lbs.



S-2002-IR

SPECIFICATIONS
 240 Volts
 18 Amps
 39" Heads
 227 lbs.

MODEL S-2002-IR

Part No. 16-1035

- Same quality features as S-2002 but includes an infrared sensor that allows the technician to select and maintain a predetermined surface temperature until the curing process is complete
- Digital controls (See page 3) provide complete accuracy and are easy for the technician to set up and operate

Portable Medium Wave Systems

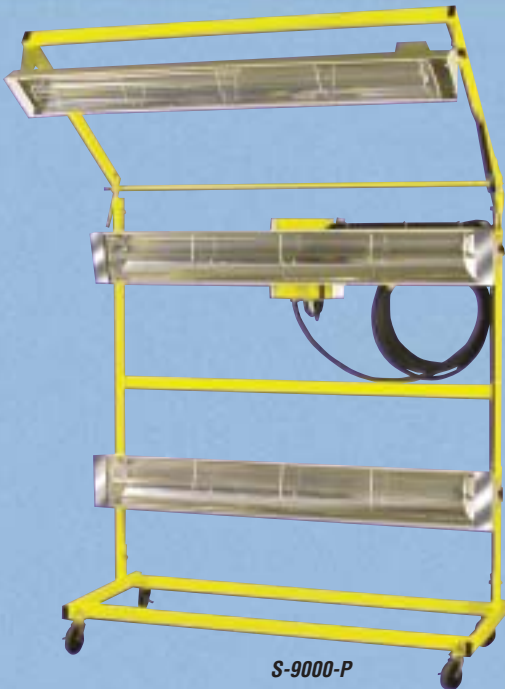

S-9000-P

MODEL S-9000-P

Part No. 14-1100

- 9000 Watts of Medium Wave Infrared Curing with a huge 6' X 8' coverage area
- Three zone, solid state, programmable controls with electronic timer
- Independently control curing heads from 0-100% for maximum efficiency (3000 Watts each)
- Narrow frame profile designed to fit in spray booths
- Adjustable shock arm to reach high areas easily
- 3 phase units and 208 voltage units also available
- Equipped with 50' power cord
- Underwriters Laboratories (U.L.) Listed

SPECIFICATIONS

240 Volts
38 Amps
61" Heads
200 lbs.



MODEL S-2005

Part No. 16-1030

- Largest coverage available from any portable Medium Wave unit
- 17,000 Watts of curing power
- Independently control the top (4000 Watts each) and bottom curing heads (3000 Watts each)
- Dual solid state, programmable controls with electronic timers
- Adjustable shock arm and narrow frame profile to fit in spray booths
- Equipped with 50' power cord
- Underwriters Laboratories (U.L.) Listed

MODEL S-2005-IR

Part No. 16-1040

- Same quality features as S-2005 but includes an infrared sensor that allows a predetermined surface temperature to be maintained throughout the curing process

SPECIFICATIONS

240 Volts
38 Amps
61" Heads
285 lbs.

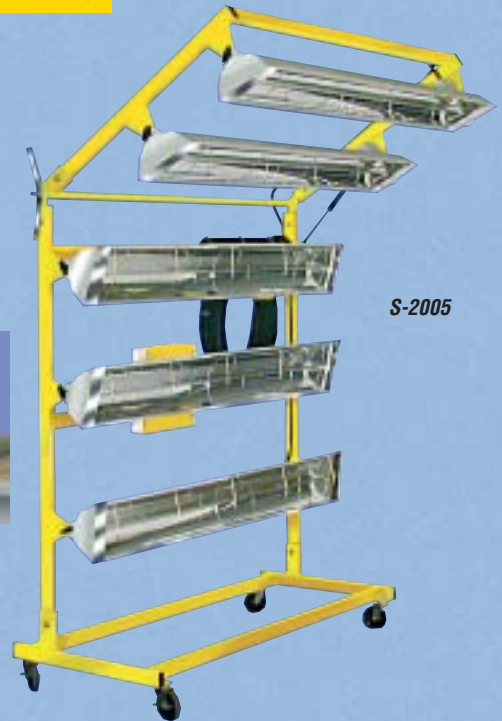

S-2005

Precision Programmable Digital Controls for Most Portable Models

CONTROL PANEL FOR:
S-2002-IR SR-IV-IR
S-2005-IR SR-VI-IR



CONTROL PANEL FOR:
S-2002 SR-IV
S-2005 SR-VI



CONTROL PANEL FOR:
S-9000-P

- User friendly – easy to set-up, easy to maintain
- Precise readings in large LED display
- Includes half-power flash time function
- Set cure times at desired temperature levels
- Variable intensity levels (0-100%)
- Sensor controls allow calibration by technician

Portable Short Wave Systems

SRII-C100

Part No. 17-1000

- IRIDIUM Short Wave unit offers faster cure times
- 2000 Watts of short wave infrared curing over a 3' X 4' coverage area
- IRIDIUM enhanced quartz halogen element puts more energy into the work and less into visible light
- Parabolic reflector for uniform heat distribution
- Vertical or horizontal operation for curing hard to reach areas and increased flexibility for small repairs
- Heavy duty stand adjusts to over 6' high
- Energy efficient, only pennies per hour to operate
- Underwriters Laboratories (U.L.) Listed

SRII-C200

Part No. 17-1010

- Same quality features as SRII-C100 with more sophisticated controls
- 2000 Watts of short wave infrared with solid state controls allows for adjustment of heat output (0-100%) to minimize the possibility of paint film damage or solvent popping
- 60 minute timer saves energy and turns off unit when curing is complete
- Includes selector switch for two-minute flash time at half-power.
- Underwriters Laboratories (U.L.) Listed

MODEL SR-IV

Part No. 17-1200

- IRIDIUM Short Wave 4000 Watt unit offers faster cure times
- Solid state, programmable controls with electronic timer
- IRIDIUM enhanced quartz halogen element puts more energy into the work and less into visible light
- Large coverage area (4' X 4')
- Parabolic reflectors for uniform heat distribution
- Adjustable shock arm extends to over 7' high
- Stand with locking casters has a narrow foot print for mobility
- Equipped with 25' power cord
- Underwriters Laboratories (U.L.) Listed

MODEL SR-IV-IR

Part No. 17-1250

- Same quality features as SR-IV but includes an infrared sensor that allows the technician to select and maintain a predetermined surface temperature until the curing process is complete
- Digital controls (See page 5) provide complete accuracy and are easy to set up and operate

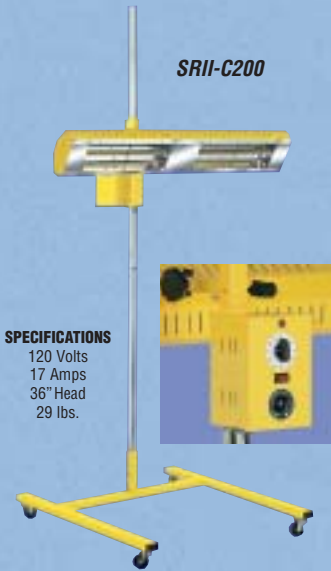

MODEL SR-VI

Part No. 17-1300

- IRIDIUM Short Wave 6000 Watt unit offers faster cure times
- Solid state, programmable controls with electronic timer
- IRIDIUM enhanced quartz halogen element puts more energy into the work and less into visible light
- Large coverage area (4' X 6')
- Adjustable shock arm extends to over 7' high
- Equipped with 25' power cord
- Underwriters Laboratories (U.L.) Listed

MODEL SR-VI-IR

Part No. 17-1350

- Same quality features as SR-VI but includes an infrared sensor that allows the technician to select and maintain a predetermined surface temperature until the curing is complete
- Digital controls (See page 5) provide complete accuracy and are easy to set up and operate

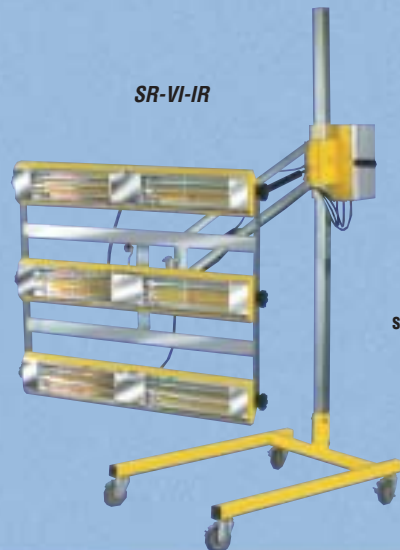

H06000-P Portable Powder Curing System

Concentrated Power When and Where You Need It!

The Infratech HO 6000-P is a new product, designed primarily as a low cost system for prototype work, maintenance, and short run powder coating. It is a medium wave high output portable infrared heater that requires virtually no installation when used as a portable system. It is fully capable of curing powder on parts many times it's own size and weight. By simply moving it along as the powder cures it can cure large parts. Two or more of the HO 6000-P units can also increase the efficiency of any curing process using a conveyor and a continuous corridor gas convection oven for product finishing. By preheating parts before entering the powder booth and/or preheating the parts before they

enter the convection oven, the curing process begins more quickly and effectively. This means that overall curing time is reduced, productivity is increased and product quality improved.

There are many other uses for the HO 6000-P. Curing Teflon coatings or any high temperature coating.

- Preheating cast iron before welding
- Melting snow and ice
- Thawing frozen valves
- Heating plastic and laminates for forming or molding
- Preheating the molds for fiberglass and carbon fiber products and curing the resins

Assortments of add on controls give you the ability to control the intensity, the on time and even the surface temperature of your parts. There is a control just right for your specific application.

Infratech is the international leader in full-range infrared technology. We use a practical approach in applying our infra-red, thoroughly satisfying your process requirements.

Infratech provides infinitely adjustable electric infrared for accurate and uniform product heating.

- CURE POWDER
- CURE TEFLON
- CURE CARBON FIBRE
- SHORT CURE TIMES
- FORM PLASTICS
- CURE ADHESIVES
- MELT SNOW & ICE
- MAINTENANCE WORK
- 6000 WATTS
- 240 VOLTS
- PORTABLE
- INDUSTRIAL QUALITY
- LOW COST
- SWITCH AND CORD INCLUDED
- ROTATES HORIZONTAL OR VERTICAL
- ADJUSTABLE TO OVER 6' HIGH

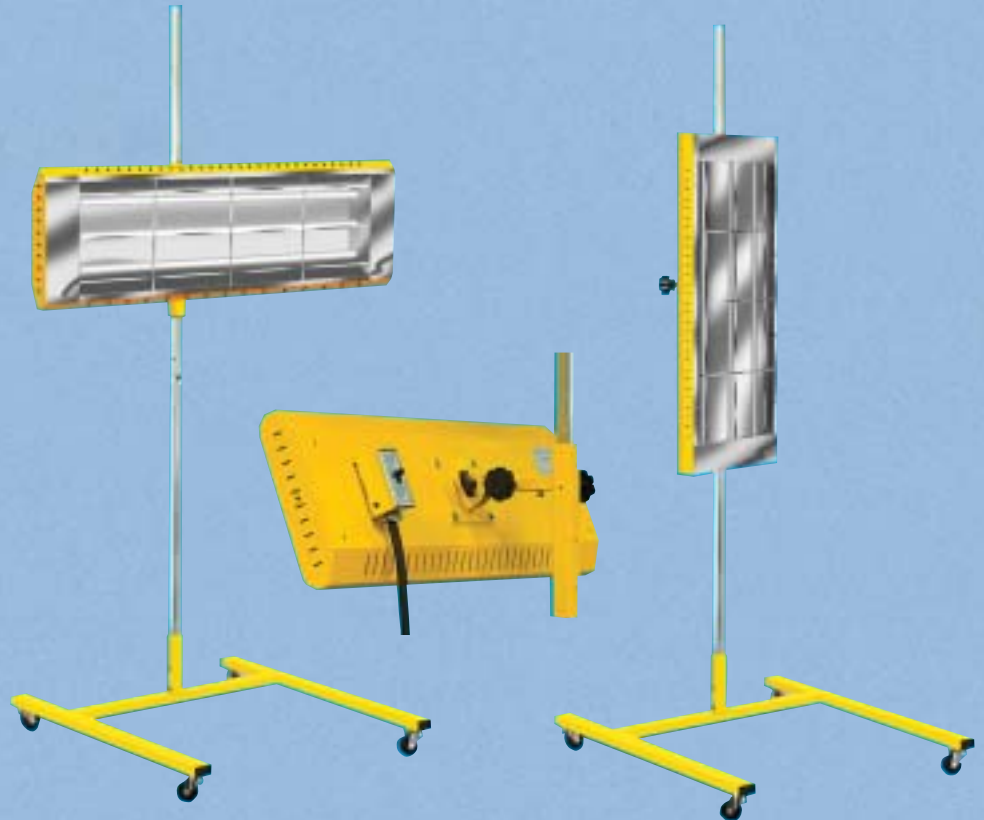

Optional Digital Controller available in six different models. Options include timer and solid state relay zone control. Units can be order in a surface mount configuration for use with permanently installed fixtures or to mount on the crossarm of the HO 6000-P.



Optional infrared sensor available only on the one-zone digital control. May be focused on the target to allow the solid state control to hold surface temperatures plus or minus 3 degrees fahrenheit.

INFRATUBE™ Medium Wave Industrial Infrared Heaters

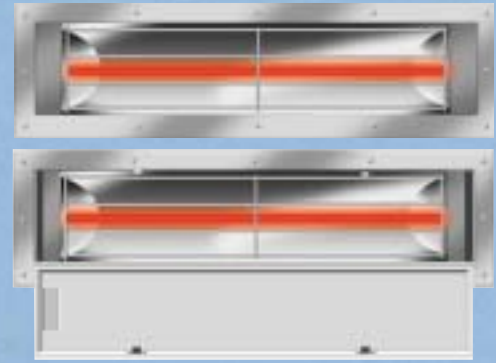
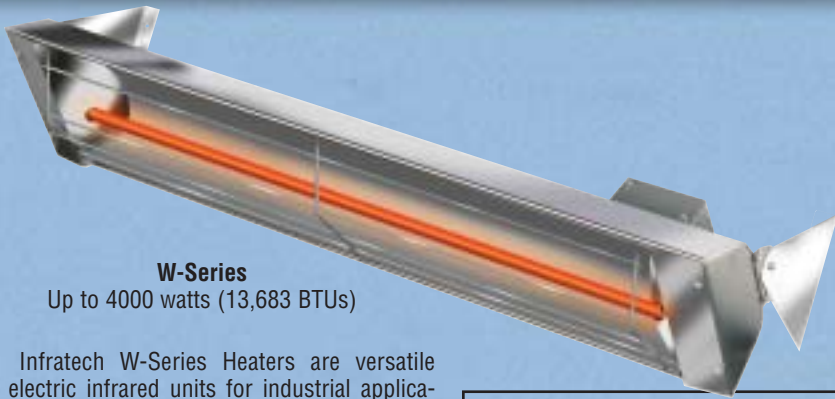

W-Series

Up to 4000 watts (13,683 BTUs)

Infratech W-Series Heaters are versatile electric infrared units for industrial application. The fixtures can be used on open frames or integrated into existing oven enclosures.

Electric infrared curing enhances manufacturing processes and typically improves finish quality and adhesion. Electric infrared curing works well with virtually all air dry coatings including primers, sealers, base coats, stains, varnishes, clear coats, adhesives, and top coats.

The Infratube fixtures are compact and energy efficient with a curved parabolic reflector to uniformly distribute heat. These fixtures are reliable with no moving parts and long lasting tubular quartz infrared heating elements.

Infratube fixtures are easy to install and have a variety of mounting options that include flush mount frames and surface mount brackets.

All Infratech units are UL Listed and are available with a wide variety of UL Listed control options. One year Limited Manufacturer's Warranty on all equipment.

Powder Coated Fixtures (Beige)

| Part No. | Description | Length | BTUs | Watts | Volts | Amps | Ship Wt. |
|----------|----------------|---------|--------|-------|-------|------|----------|
| 22-1040 | W-1512 Fixture | 33" | 5,118 | 1,500 | 120 | 12.5 | 12 |
| 22-1045 | W-1524 Fixture | 33" | 5,118 | 1,500 | 240 | 6.3 | 12 |
| 22-1055 | W-2024 Fixture | 39" | 6,824 | 2,000 | 240 | 8.4 | 13 |
| 22-1100 | W-3024 Fixture | 61 1/4" | 10,236 | 3,000 | 240 | 12.5 | 20 |
| 22-1125 | W-4024 Fixture | 61 1/4" | 13,648 | 4,000 | 240 | 16.7 | 20 |

Dual-Element Powder Coated Fixtures (Beige)

| Part No. | Description | Length | BTUs | Watts | Volts | Amps | Ship Wt. |
|----------|-----------------|---------|--------|-------|-------|------|----------|
| 22-2100 | WD-4024 Fixture | 39" | 13,648 | 4,000 | 240 | 16.7 | 14 |
| 22-2200 | WD-5024 Fixture | 39" | 17,060 | 5,000 | 240 | 20.8 | 14 |
| 22-2300 | WD-6024 Fixture | 61 1/4" | 20,472 | 6,000 | 240 | 25 | 22 |
| 22-2400 | WD-8024 Fixture | 61 1/4" | 27,296 | 8,000 | 240 | 33.4 | 22 |

Stainless Steel Fixtures

| Part No. | Description | Length | BTUs | Watts | Volts | Amps | Ship Wt. |
|----------|-------------------|---------|--------|-------|-------|------|----------|
| 21-1040 | W-1512-SS Fixture | 33" | 5,118 | 1,500 | 120 | 12.5 | 12 |
| 21-1045 | W-1524-SS Fixture | 33" | 5,118 | 1,500 | 240 | 6.3 | 12 |
| 21-1055 | W-2024-SS Fixture | 39" | 6,824 | 2,000 | 240 | 8.4 | 13 |
| 21-1100 | W-3024-SS Fixture | 61 1/4" | 10,236 | 3,000 | 240 | 12.5 | 20 |
| 21-1125 | W-4024-SS Fixture | 61 1/4" | 13,648 | 4,000 | 240 | 16.7 | 20 |

Dual Element Stainless Steel Fixtures

| Part No. | Description | Length | BTUs | Watts | Volts | Amps | Ship Wt. |
|----------|--------------------|---------|--------|-------|-------|------|----------|
| 21-2100 | WD-4024-SS Fixture | 39" | 13,648 | 4,000 | 240 | 16.7 | 14 |
| 21-2200 | WD-5024-SS Fixture | 39" | 17,060 | 5,000 | 240 | 20.8 | 14 |
| 21-2300 | WD-6024-SS Fixture | 61 1/4" | 20,472 | 6,000 | 240 | 25 | 22 |
| 21-2400 | WD-8024-SS Fixture | 61 1/4" | 27,296 | 8,000 | 240 | 33.4 | 22 |

208v, 277v, and 480v heaters are available by special order.

Parts and Accessories

| Part # | Model # | Description | Ship Wt. |
|---------|----------------------|------------------------------------------------------|----------|
| 10-1065 | E-1512 Element | E-1512 Element Fits WD & W-1512 Heater | 6 |
| 10-1070 | E-1524 Element | E-1524 Element Fits WD & W-1524 Heater | 6 |
| 10-1085 | E-2024 Element | E-2024 Element Fits WD & W-2024 Heater | 8 |
| 10-2030 | E-3024 Element | E-3024 Element Fits WD & W-3024 Heater | 11 |
| 10-2055 | E-4024 Element | E-4024 Element Fits WD & W-4024 Heater | 11 |
| 13-1260 | Wall Mount | Wall Mounting Bracket | 3 |
| 14-4092 | INF-10 (120V) | Variable Intensity Control | 2 |
| 14-4094 | INF-20 (240V) | Variable Intensity Control | 2 |
| 22-1250 | Pole Mount | Freestanding Heater Mount | 60 |
| 22-1260 | Pole Mount w/INF Box | Freestanding Heater Mount | 62 |
| 18-2300 | W-20 Special Mount | Flush Plaster Ceiling Mount | 18 |
| 18-2305 | W-30 Special Mount | Flush Plaster Ceiling Mount | 21 |
| 18-2310 | W-20 Special Mount | Flush T-Bar Ceiling Mount | 18 |
| 18-2315 | W-30 Special Mount | Flush T-Bar Ceiling Mount | 21 |
| 30-4000 | CH-50 Control | Analog 50 Amp Intensity Control | 25 |
| 30-4005 | DC-150 Control | Digital 50 Amp 1-Zone Intensity Control | 45 |
| 30-4010 | DCT-150 Control | Digital 1-Zone Control w/Timer | 45 |
| 30-4015 | DCIR-150 Control | IR Thermocouple Control, Sensor Not Included | 45 |
| 30-4020 | DCIRT-150 Control | IR Thermocouple Control w/Timer, Sensor Not Included | 45 |
| 30-4025 | DC-350 Control | Digital 3-Zone Intensity Control | 45 |
| 30-4030 | DCT350 Control | Digital 3-Zone Control w/Timer | 45 |



Many different controls are available; from a simple, cost effective Input Regulator to state of the art digital solid state and analog controls with multiple zones, timers, and non-contact infrared thermocouples.

Infratech Infratube Fixtures are commonly used in many applications such as:

- **Woodworking**
- **Laminating**
- **Web Processing**
- **Shrink Wrap**
- **Pre-Heating**
- **Plastic Forming**
- **Dry Off**
- **Spot Curing**
- **Powder Coating**
- **Automotive Refinishing**

INFRATUBE™ Medium Wave Industrial Infrared Panels

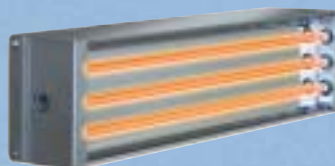

Infratech Electric Infrared Heat Panels are versatile high intensity units for industrial and commercial applications. Panels are designed with a maximum operating temperature of 450 degrees fahrenheit.

Infratech Heat Panels are constructed of 18 gauge, aluminized steel with polished stainless steel reflectors. The fixtures can be used on open frames or integrated into existing oven enclosures. The insulated fixtures can also be used as the exterior oven walls.

Electric infrared curing offers the fastest cure times and generally improves finish quality and adhesion. Infrared curing works well with virtually all air dry and heat cured coatings including primers, alkyds, enamels, stains, adhesives, top coats, and powder.

The fixtures are energy efficient and cover large areas with curved reflectors to uniformly distribute heat. These fixtures are reliable with no moving parts and long lasting tubular quartz infrared heating elements.

Heat Panels are manufactured to customer specifications, with a wide variety of wattages, voltages, and single or 3-phase options. In addition, customers can use the junction box and mounting options to reduce installation time and expenses.

UL Listed industrial controls are available for precise heat output regulation and process control. One year Limited Manufacturer's Warranty on all equipment.



Many different controls are available; including state of the art digital solid state and analog controls with single zone, multiple zones, timers, and non-contact infrared thermocouples.

Infratech Heat Panels are commonly used in many applications such as:

- **Plastic Forming**
- **Dry Off**
- **Spot Curing**
- **Pre-Gel Ovens**
- **Automotive Refinishing**
- **Powder Coating**
- **Laminating**
- **Web Processing**
- **Shrink Wrap**
- **Pre-Heating**



Industrial Infrared Panels Item List

| Part # | Model # | Description | Ship Wt. |
|-----------|-------------------|------------------------------------------------------|----------|
| X-26-1000 | G-348 | Gable Panel 48", Elements Not Included | 45 |
| X-26-1010 | F-348 | Flat Panel 12"x48", Elements Not Included | 45 |
| X-26-1020 | F-948 | Flat Panel 30"x48", Elements Not Included | 65 |
| X-26-1040 | B100 | Add for each muffin fan installed | |
| X-26-1045 | SFF2-12 | Add for each foot over 2' of 12 ga. lead wire | |
| X-26-1046 | SFF2-10 | Add for each foot over 2' of 12 ga. lead wire | |
| X-10-4035 | | Element for 48" Panel, Specify Watts and Volts | 1 |
| X-10-4040 | | Element for 60" Panel, Specify Watts and Volts | 1 |
| X-10-4045 | | Element for 72" Panel, Specify Watts and Volts | 1 |
| X-26-2062 | | Element Hooks, H Style | |
| X-26-2065 | | Buss Bar for Heat Panels | |
| X-26-2070 | | L Bracket | |
| X-30-4000 | CH-50 Control | Analog 50 Amp 1-Zone Intensity Control | 25 |
| X-30-4005 | DC-150 Control | Digital 50 Amp 1-Zone Intensity Control | 45 |
| X-30-4010 | DCT-150 Control | Digital 1-Zone Control w/Timer | 45 |
| X-30-4015 | DCIR-150 Control | IR Thermocouple Control, Sensor Not Included | 45 |
| X-30-4020 | DCIRT-150 Control | IR Thermocouple Control w/Timer, Sensor Not Included | 45 |
| X-30-4025 | DC-350 Control | Digital 3-Zone Intensity Control | 45 |
| X-30-4030 | DCT-350 Control | Digital 3-Zone Control w/Timer | 45 |

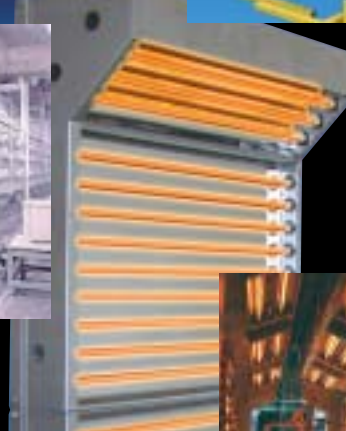
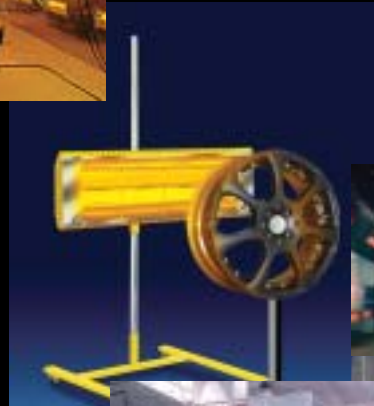

INFRATECH™

a SEACHROME company

Infratech-USA
939 North Vernon Avenue, Azusa, CA 91702 USA
626-334-3252 • Fax 800-444-3380
www.infratech-usa.com

© Seachrome Corporation 2003 All Rights Reserved